

09/20

TECHNICAL BULLETIN 8

Modeling DuraFuse Frames Connections in ETABS

Amy J. McCall, PhD, PE, LEED AP¹ and Paul Richards, PhD, PE²

Abstract: The software ETABS is sometimes used to model steel moment resisting frames. When DuraFuse Frames are used for the steel moment frame, the joints in the ETABS model should be defined to accurately reflect the behavior of the DuraFuse Frames connections. The beam-to-column connection at each joint is considered to be fully restrained (FR) and the panel zone stiffness is modeled using the scissor method or plain rigid end offsets, following procedures recommended in the literature.

Introduction

Connection modeling procedures for moment frames are governed by ASCE/SEI 7-16 § 12.7.3b (ASCE, 2016), ANSI/AISC 360-16 § B3.4 (AISC, 2016a), and precedents in ANSI/AISC 358-16 (AISC, 2016b). Basic requirements are that the panel zone deformations be explicitly considered in all models that are used for drift calculations (ASCE, 2016) and that the connection stiffness be explicitly considered unless the connection is fully restrained (FR) (AISC 2016a).

With regards to the panel zone, the most common mathematical models for representing panel zone deformations are the Krawinkler model and the scissor model. Charney and Marshall (2006) provide a thorough description of both models and derive the spring constants for both models. Fig. 1 illustrates the scissor model. Charney and Marshall (2006) demonstrate that the scissor model gives equivalent results as the Krawinkler model if the spring stiffness is defined correctly. ETABS employs the scissor model when a panel zone spring stiffness is assigned.

With regards to the beam-column connection itself, when connections are fully restrained (FR), it is not necessary to introduce a spring between the beam and column elements in the model. The DuraFuse Frames connection has been shown through experimental testing to be a fully-restrained (FR) connection (Richards, 2020). In some DuraFuse Frames configurations, connection plate material increases the flexural stiffness at the end of the beam.

The software ETABS has built-in features that enable the DuraFuse Frames connection to be modeled. The purpose of this bulletin is to explain how those features can be employed.

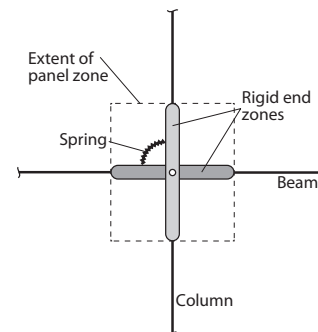

Fig. 1 Scissor model for representing panel zone deformations in drift models

ETABS Connection Definition

The standard moment frame connection in ETABS is a fully restrained (FR) connection. Since DuraFuse Frames have been shown by experimental testing and finite element analysis to be FR (Richards, 2020), they can be represented with the standard connection in ETABS (Fig. 2). In some cases, the ends of the beam near the connection have added stiffness because of the additional plate material at the connection. It is conservative to neglect those benefits and those cases are beyond the scope of this bulletin.

1 Development Engineer, DuraFuse Frames, 5801 West Wells Park Road, West Jordan, UT 84081. Email: amy.mccall@durafuseframes.com
 2 Vice President, DuraFuse Frames, 5801 West Wells Park Road, West Jordan, UT 84081. Email: paul.richards@durafuseframes.com

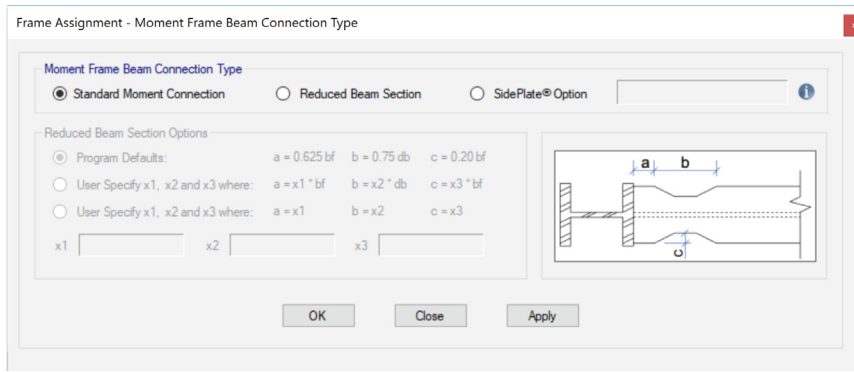

Fig. 2 Assigning a standard moment connection in ETABS to represent DuraFuse Frames

Panel Zone Rigid End Offsets

When the scissor model is used to represent the panel zone stiffness, the beam(s) and columns(s) framing into the joint should have rigid end offsets assigned (Fig. 1). Depending on the method used, end offset assignments may vary. The procedure is to choose the beams and columns entering the joint, and assign the length of the rigid end zone, corresponding to the pertinent panel zone dimension (Fig. 3, Fig. 4 and Fig. 5). Enter the rigid end zone length in End-I or End-J, depending on which end of the member frames into the joint (Fig. 3).

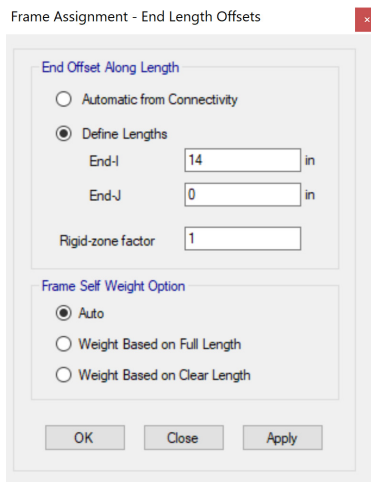
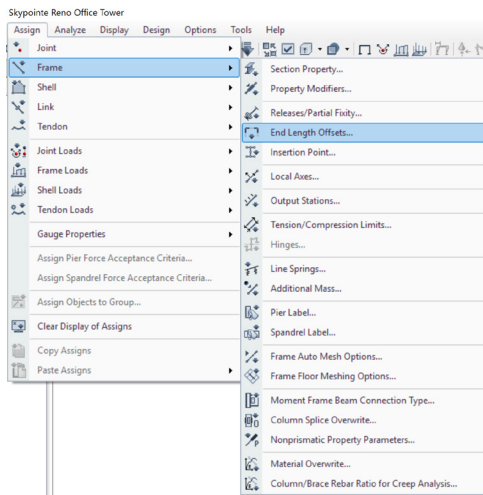

Fig. 3 Method for specifying the length of the rigid end zones in ETABS

If a Centerline method has been assumed in the model (Fig. 4), end offsets for beams and columns are $d_c/2$ and $d_b/2$, respectively. If a beam frames into a column at both ends, the same or different rigid end offsets may apply at the i and j ends. If the column is at the first floor, where beams do not frame into the bottom end of the column, a rigid end offset will only apply at the top of the column.

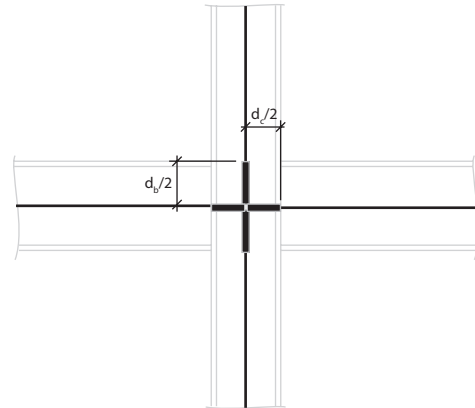

Fig. 4 Rigid end zone lengths for steel moment frame joints using the Centerline method

If a Top-Center method has been used in the model (Fig. 5), end offsets for beams and columns are $d_c/2$ and d_b , respectively.

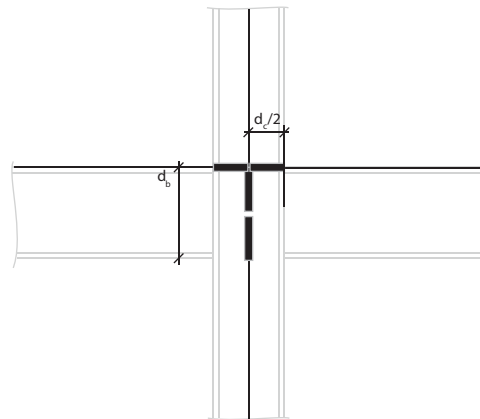

Fig. 5 Rigid end zone lengths for steel moment frame joints using the Top-Center method

Note: If the user selects “Automatic from Connectivity” (Fig. 6), the column rigid end zone region is set to d_b by default (Top-Center method), not $d_b/2$. The user should be clear on which method they are using.

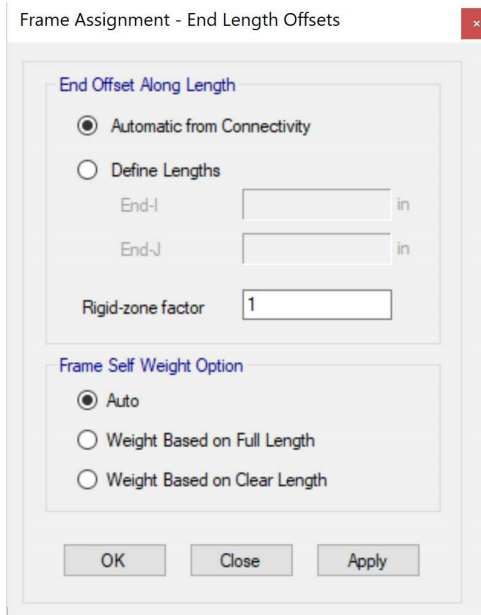

Fig. 6 Automatic end offsets in ETABS assume the Top-Center Method

The rigid-zone factor should be set to 1.0 (Fig. 3) for the beam and column end zones when the scissor model is being used to represent the panel zone (Fig. 1). Otherwise, panel zone flexibility is added twice, through the end zones and through the spring.

In some cases, the DuraFuse Frames cover plates may extend a distance beyond the panel zone. It may be appropriate to consider the rigid end zone for the columns to be greater than $d_b/2$ in those situations.

Panel Zones

When panel zones are stiffened with cover plates, the panel zone contributions to story drift are diminished. In many cases, the contributions are small enough that they do not have to be considered explicitly.

ASCE 41-17 provides guidance on how stiff a panel zone should be in order to not have to consider the contributions explicitly. ASCE 41-17 9.4.2.2.1.3 says: “Where the expected shear strength of the panel zone exceeds the flexural strength of the beams at the beam-to-column connection, and the stiffness of the panel zone (converted to a rotational spring) is at least 10 times larger than the flexural stiffness of the beam, direct modeling of the panel zone shall not be required. In such cases, rigid offsets from the center of the column shall be permitted to represent the effective span of the beam.”

This approach to panel zones is similar to the approach for modeling steel connection stiffness. Connections with sufficient stiffness to be classified as fully restrained (FR) are permitted to be modeled as rigid, while those that are classified as partially restrained (PR) must have a spring included in the model to represent the connection flexibility.

DuraFuse joints always meet the strength criterion of ASCE 41-17 9.4.2.2.1.3 and can be designed to ensure that the stiffness criterion of that section is met. This can simplify member sizing since 100% rigid offsets in the panel zone can be assumed and panel zone springs do not need to be assigned to every joint. When engineers choose to model with rigid panel zones, DuraFuse Frames engineers will provide the calculations to justify the assumption per ASCE 41-17 9.4.2.2.1.3.

If the engineer prefers to explicitly model the panel zone stiffness, please contact DuraFuse Frames for instructions on calculating panel zone spring stiffness.

Conclusions

This note has described the way that the DuraFuse Frames connection can be accurately modeled in ETABS. The beam-to-column connection is considered to be fully restrained (FR) and the panel zone stiffness is modeled with the scissor method or plain rigid end offsets, following procedures recommended in the literature. The modeling procedures are conservative for cases where the DuraFuse connection plates stiffen the beam and column beyond the extends of the panel zone.

References

- AISC (2016a). “Specification for Structural Steel Buildings,” AISC (2016a). “Specification for Structural Steel Buildings,” AISC 360, American Institute of Steel Construction, Chicago, IL.
- AISC (2016b). “Prequalified Connections for Special and Intermediate Steel Moment Frames for Seismic Applications,” AISC 358, American Institute of Steel Construction, Chicago, IL.
- ASCE (2016). “Minimum Design Loads and Associated Criteria for Buildings and Other Structures,” ASCE 7, American Society of Civil Engineers, Reston, VA.
- ASCE (2017). “Seismic Evaluation and Retrofit of Existing Buildings,” ASCE 41, American Society of Civil Engineers, Reston, VA.
- Charney, F. A., and Marshall, J. (2006). “A Comparison of the Krawinkler and Scissors Models for Including Beam-Column Joint Deformations in the Analysis of Moment-Resisting Steel Frames,” *Engineering Journal*, AISC, 42(1), 31-48.
- Richards, P. W. (2020). “Quantifying Connection Rigidity in DuraFuse Frames,” *Technical Bulletin 4*, DuraFuse Frames, West Jordan, UT.



IAPMO UES ER 610



THE RESILIENT SEISMIC SOLUTION

All rights reserved. For informational purposes only. Durafuse Frames reserves the right to alter or withdraw the bulletin content without notice.